

# Artistic

SKYLIGHT DOMES

RESIDENTIAL & COMMERCIAL SKYLIGHTS



THE BRIGHTER  
ALTERNATIVE



[artisticskylight.com](http://artisticskylight.com)

255 Regina Road, Woodbridge, ON L4L 8M3, 1-866-878-DOME (3663)

## COMPANY PROFILE

Backed by over 50 years of experience in skylight manufacturing, Artistic Skylight Domes Ltd. is a proud Canadian manufacturer of standard and custom skylights. To maintain our high levels of quality control, our management team uses a hands on approach as well as using state of the art machinery for all our in-house manufacturing. As part of our ongoing commitment to our customers we strive to provide quality products, customer service and satisfaction second to none.

All Artistic Skylights meet or exceed Canadian Government Specifications (CAN/CGSB-63, 14-M89) and are available in a large selection of standard sizes as well as a wide variety of custom sizes, shapes and colours for all residential, commercial and industrial applications.

## DESIGN SUPPORT

Our well experienced staff is always available to promptly deal with all inquiries regarding technical information, details and budgeting. With the help of computer aided design we are able to quickly produce drawings for any project. As part of our design support we also provide professional installation or site supervision if required. We invite your inquiries on various custom designed skylights.



## TECHNICAL DATA

### GLAZING OPTIONS

All Artistic Skylights are available with either domed, pyramid or flat acrylic glazing, or flat glass glazing. Acrylic glazing is available in four colours:

1. #CLEAR – recommended when the maximum amount of light is desired.
2. #2447 WHITE – translucent material used for light diffusion, reduced heat and glare, and privacy.
3. #2412 BRONZE – transparent material used to reduce interior solar heat gain, control glare, and prevent bleaching of furnishings while permitting clear vision to exterior.

Material	Colour	Transmittance		Shading Coefficient
		Visible Light	Solar Heat	
Acrylic	Clear	92%	85%	.89
Acrylic	Bronze #2412	27%	35%	.43
Acrylic	White #2447	53%	52%	.44

**SPECIAL ACRYLIC COLOURS:** A wide range of transparent and translucent acrylic colours are available for special effect. Consult with Artistic Skylight Domes Ltd. for special acrylic colours.

### INSULATION (U VALUES)

Plastic glazing has one fourth the thermal conductivity of glass, therefore giving it an insulation value of approximately 20% better than standard glass. The recent advent however, of specialty glass such as low emissivity and heat mirror has drastically improved the insulation and heat transmittance of glass.

U values – BTU/hr/sq.ft.<sup>2</sup> F

3/16" thickness	winter heat loss 24 km/hr wind	summer heat gain 12 km/hr wind
single glazed	1.2	0.8
double glazed	0.7	0.5

•Values are per sq. ft. of skylight opening (not per sq. ft. of dome surface)

•Values may vary with sheet thickness

## IMPACT RESISTANCE FLAME SPREAD RATING

Tempered Glass	4 times stronger than standard glass
Acrylic	20 times stronger than standard glass
Polycarbonate	200 times stronger than standard glass

Material	Thickness	Flame Spread (GWL)	Smoke Developed
Acrylic	1/8" - 1/4"	125 - 145	400 - 500
Polycarbonate	1/8" - 1/4"	45 -60	400 - 500
Glass	Non Combustible		

## CARE and MAINTENANCE

Under normal conditions acrylic domes are self-cleaning and therefore require little maintenance due to the smooth finish and shape of the dome. However if cleaning is desired, domes may be cleaned using most household detergents or ammonia and water. DO NOT use paint thinner, turpentine or any abrasive materials for cleaning purposes. Glass skylights are much less likely to scratch or be damaged by cleaning solutions. Exercise the same cleaning methods that are used on standard glass windows.

Another component which may also require attention is the condensation gutter. To clean the condensation gutter take a damp rag and run it the length of the gutter to ensure the drain holes are free from blockage.

Data supplied and approved by "Underwriters' Laboratories of Canada" in accordance with CAN/CGSB-63, 14-M89

For further information please contact:  
**ARTISTIC SKYLIGHT DOMES LTD.**  
Woodbridge, Ontario, Canada L4L 8M3  
Tel: (416) 747-7233 Fax: (416) 747-6630





# Curb Mount Skylights (Fixed)

A long time industry standard, Models PVCCM & FF are suitable for use on all type roofs. Designed for mounting on 1 1/2" (38mm) curbs with flashing (by others), these units provide excellent performance at a comparatively low cost. Flashing kits available at extra cost.

## Model PVCCM (vinyl curb frame)

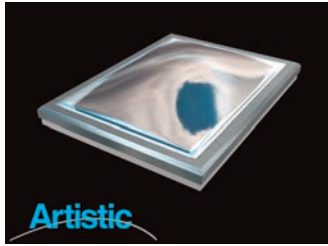

**Features:**

- Glazing available in sealed double or triple acrylic domes of clear, white, bronze
- Vinyl curb is a rigid high-impact extruded vinyl curb frame (superior in thermal conductivity to aluminum)
- Retaining cap frame shall be extruded, mill finish (optional baked enamel)

- To specify glass glazing option, add prefix "G" to model code. See table below for 'Glass Performance' options

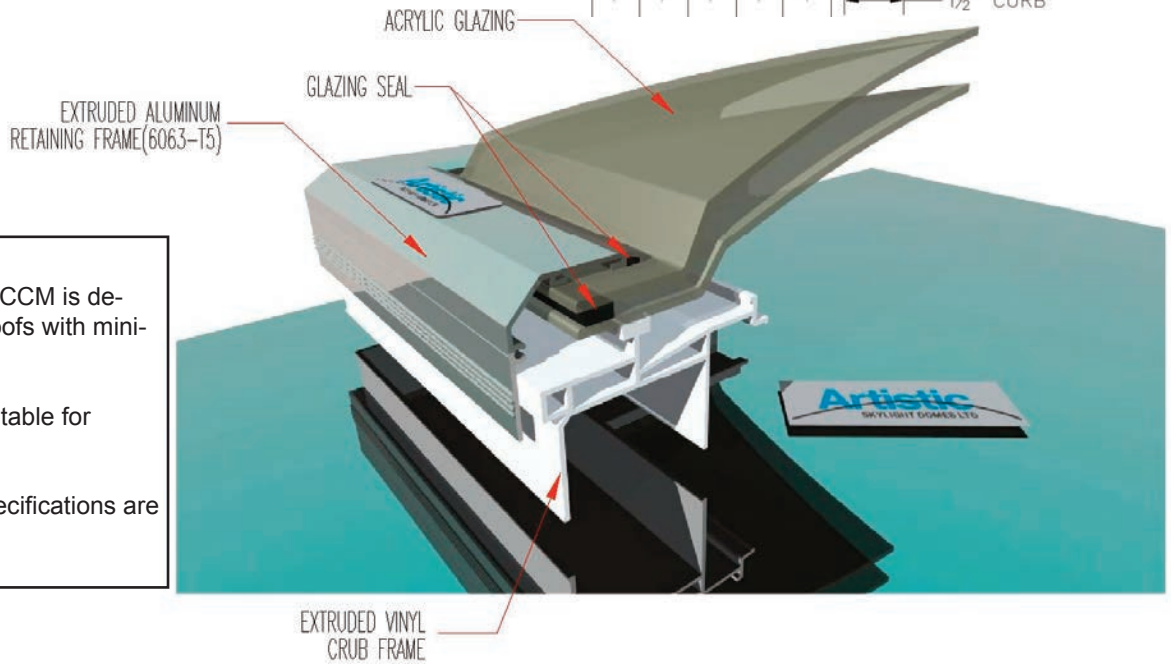
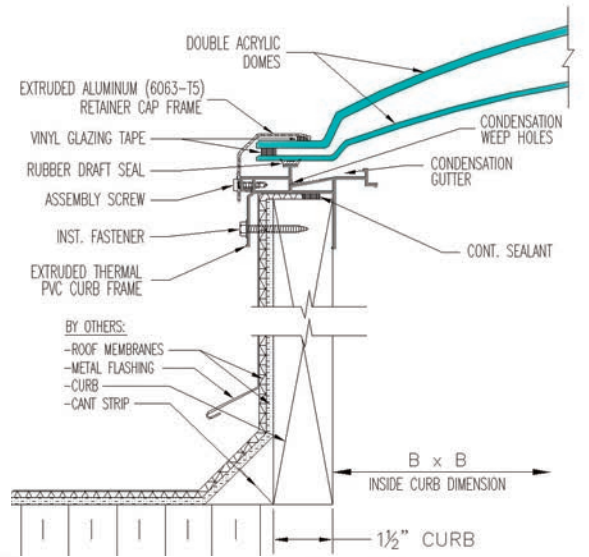

## Glass Option

Curb mount Model G-PVCCM is designed for mounting on roofs with minimum 3:12 pitch.

See 'Glass Performance' table for glass options.

Complete details and specifications are available upon request.

## MODEL G-PVCCM



### GLASS PERFORMANCE

- Insulated clear tempered (optional Low E, and Argon gas-filled)
- Insulated bronze, blue, gray, and green tempered (optional Low E and Argon gas-filled)
- Heat Mirror
- Reflective tempered glass. Tempered overlaminated glass is also available to meet Building codes in different areas. Glass is non-combustible.

**Model FF (aluminum curb frame)**

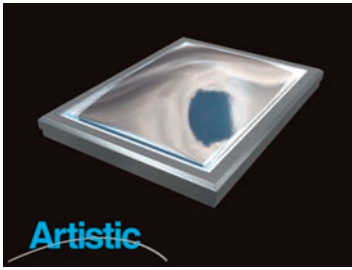

**Features:**

- Available in sealed double acrylic domes (or sealed triple domes) of clear, white, bronze
- Consisting of corrosion resistant extruded aluminum curb frame
- Curb frame shall have an extruded rigid vinyl thermal break
- Retaining cap frame shall be extruded, mill finish (optional baked enamel) aluminum alloy

- To specify glass glazing option, add prefix "G" to model code  
See page 3, for 'Glass Performance' options

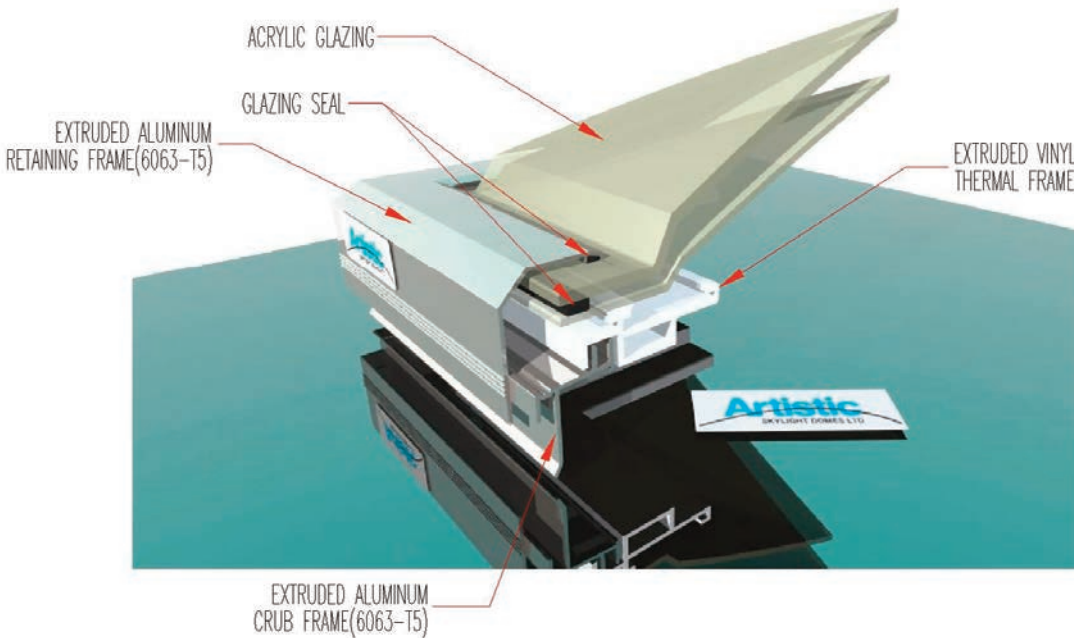
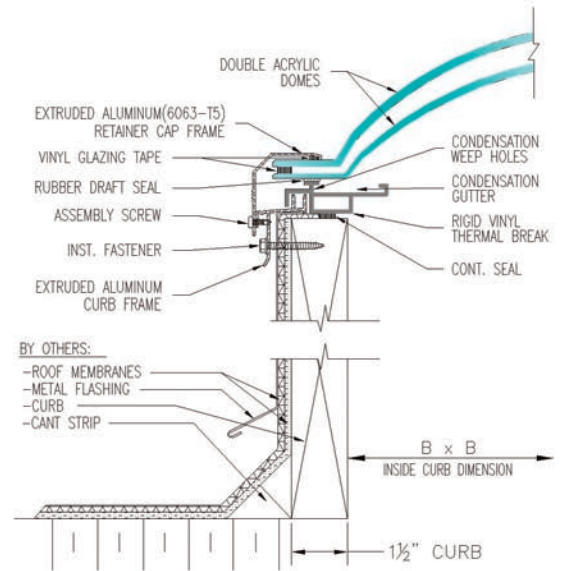

**Glass Option**  
Curb mount Model G-PVCCM is designed for mounting on roofs with minimum 3:12 pitch.  
See 'Glass Performance' table for glass options.  
Complete details and specifications are available upon request.





## Pyramid Skylights

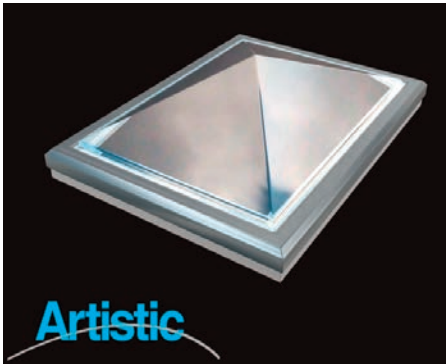

To enhance the appearance of any building we recommend specifying the Artistic Skylight pyramids. These products are available in either the vinyl or aluminum curb frame systems, with standard 30 degree slope (optional 45 degree). The pyramid configuration is also available in the Cluster or Butted system on page 15. Complete details and specifications are available upon request.

- To specify pyramid option, add prefix "P" to model PVCCM or FF
- To specify glass glazing option, add prefix "G" to model code. See page 3, for 'Glass Performance' options

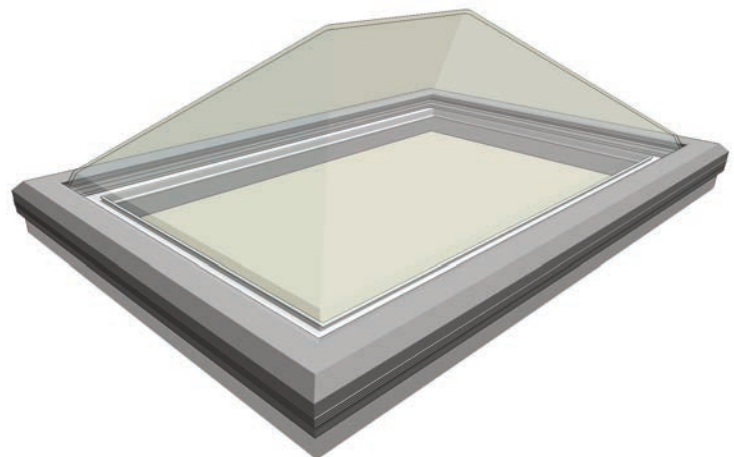
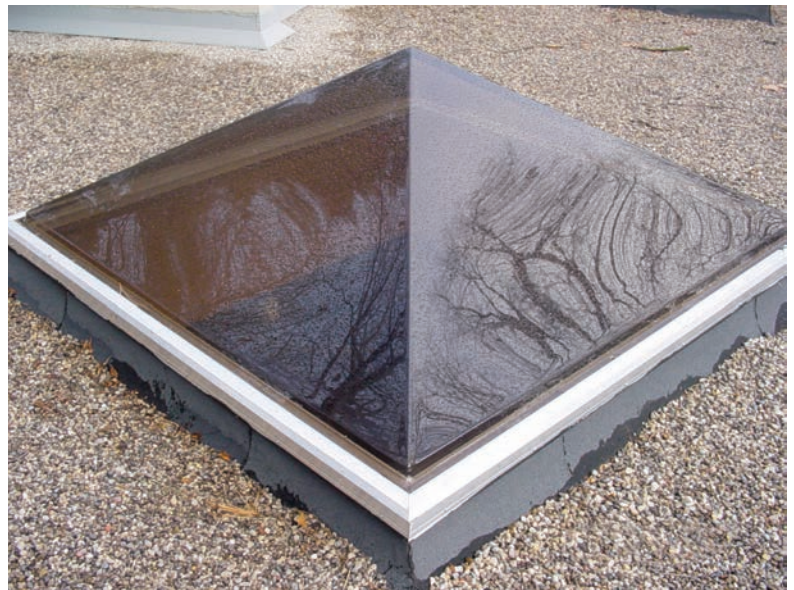
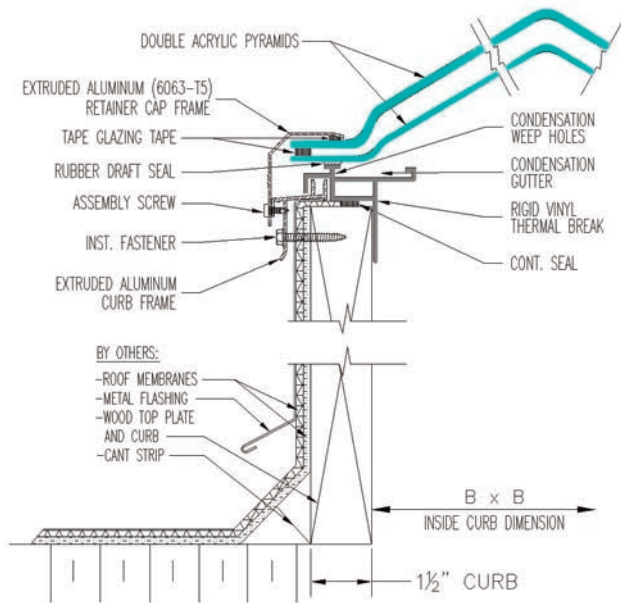

Model P-PVCCM (Ridge)

# Operable skylights (Venting)

Specifically designed for rooms which require ventilation, Model V-PVCCM & V-FF (curb mount) and Models V-PVCSR & V-SR (self flashing) come complete with manual/automated operating mechanism to open the skylight for maximum ventilation.

## Model V-PVCCM (vinyl curb frame)

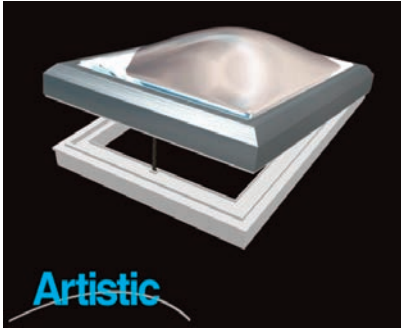

### Features:

- Available in sealed double acrylic domes (or sealed triple domes) of clear, white, bronze, grey
- Incorporating a heavy duty corrosion resistant chain drive operating mechanism, pin pivot hinge system and removable insect screen
- Consisting of rigid high-impact extruded vinyl curb frame

- Retaining cap frame shall be extruded, mill finish (optional baked enamel) aluminum alloy
- Complete details and specifications are available on Model V-FF (aluminum curb frame)
- To specify glass glazing option, add prefix "G" to model code, see page 3, for 'Glass Performance' options
- Optional features include 6'-10' manual or electric extension poles, electric and remote control system

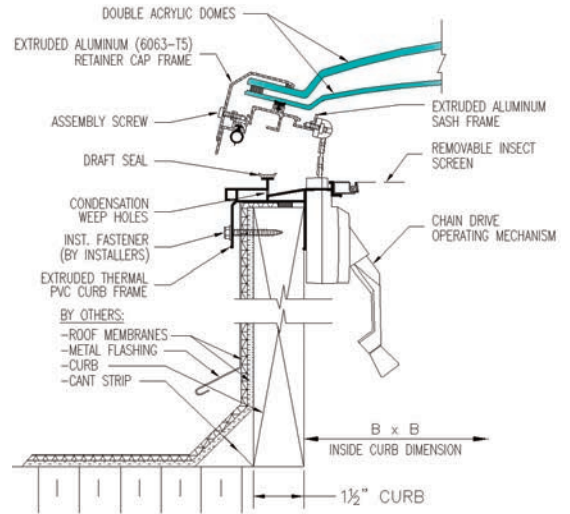

## Model GV-PVCCM (vinyl curb frame)

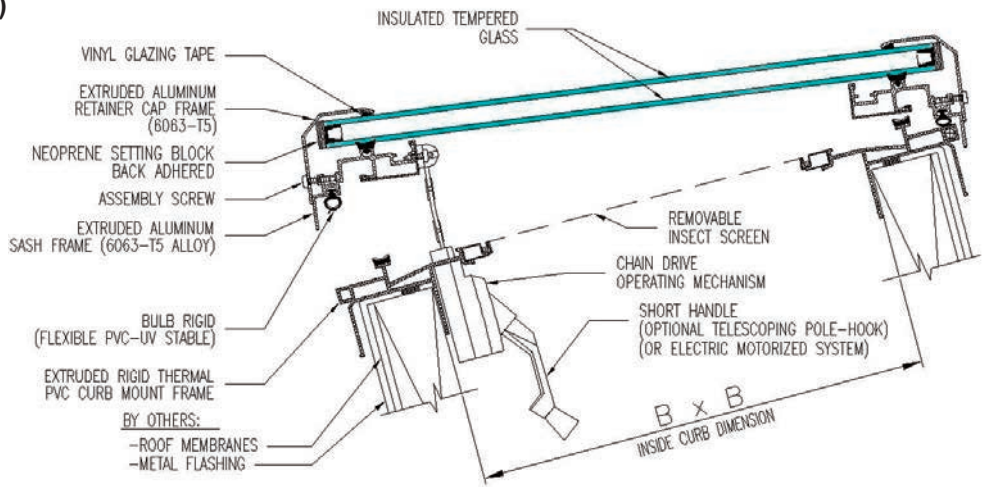
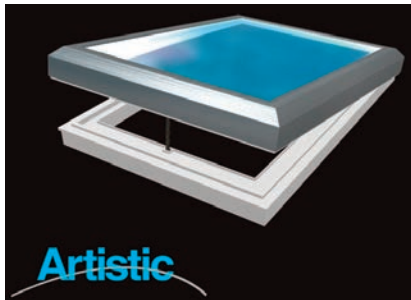

SECTION

### Features:

- Available in double high performance tempered glass glazing system, see page 3, for 'Glass Performance' options
- Consisting of rigid high-impact extruded vinyl curb frame,
- Retaining cap frame shall be extruded, mill finish (optional baked enamel) aluminum alloy

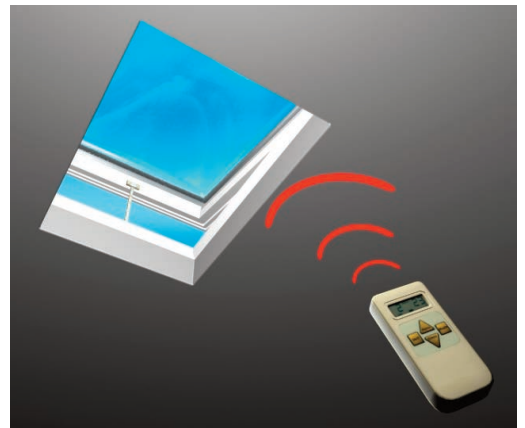

Remote controlled and Rain Sensor options on Models V-PVCCM



# Self Flashing Skylights

Models PVCSR & SR are designed to be installed on shingled roofs with minimum 3:12 pitch. These skylights mount directly over roof opening and require no curbs or metal flashings.

## Model PVCSR (vinyl base frame)

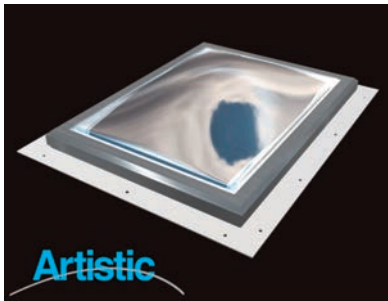

### Features:

- Available in sealed double acrylic domes (or sealed triple domes) of clear, white, bronze, grey
  - Consisting of rigid high-impact extruded vinyl base frame
  - Retaining cap frame shall be extruded, mill finish (optional baked enamel) aluminum alloy
- To specify glass glazing option, add prefix "G" to model code. See page 3, for 'Glass Performance' options

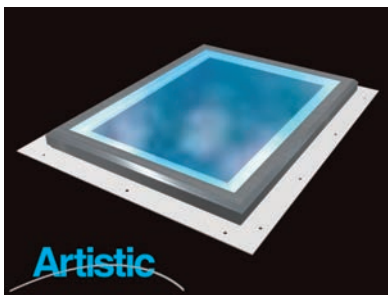

Model G-PVCSR

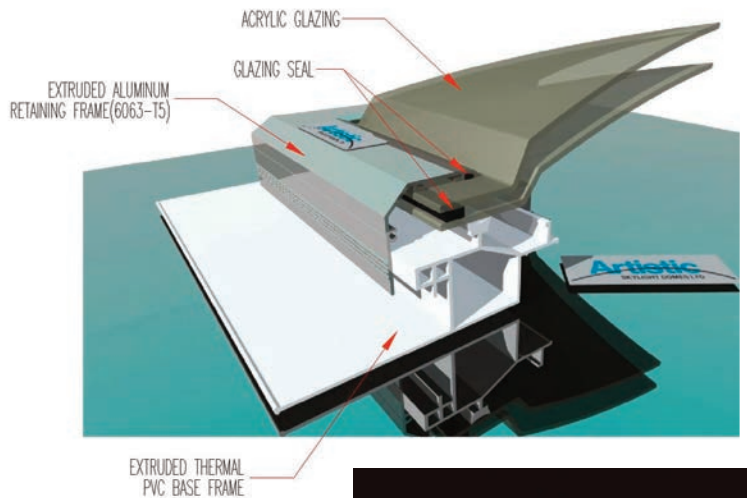

## Model SR (aluminum base frame)

### Features:

- Available in sealed double acrylic domes (or sealed triple domes) of clear, white, bronze, grey
  - Consisting of corrosion resistant extruded aluminum curb frame, 3" aluminum mounting flange
  - Base frame shall have a 2" thermal insulation and an extruded rigid vinyl thermal break frame
  - Retaining cap frame shall be extruded, mill finish (optional baked enamel) aluminum alloy
- To specify glass glazing option, add prefix "G" to model code. See page 3, for 'Glass Performance' options

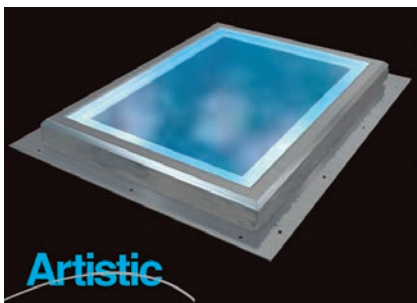
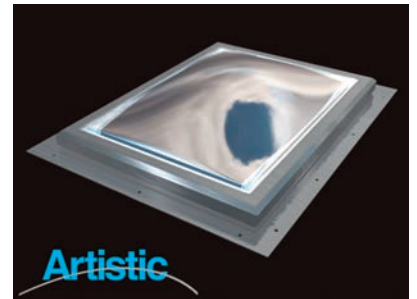

Model G-SR

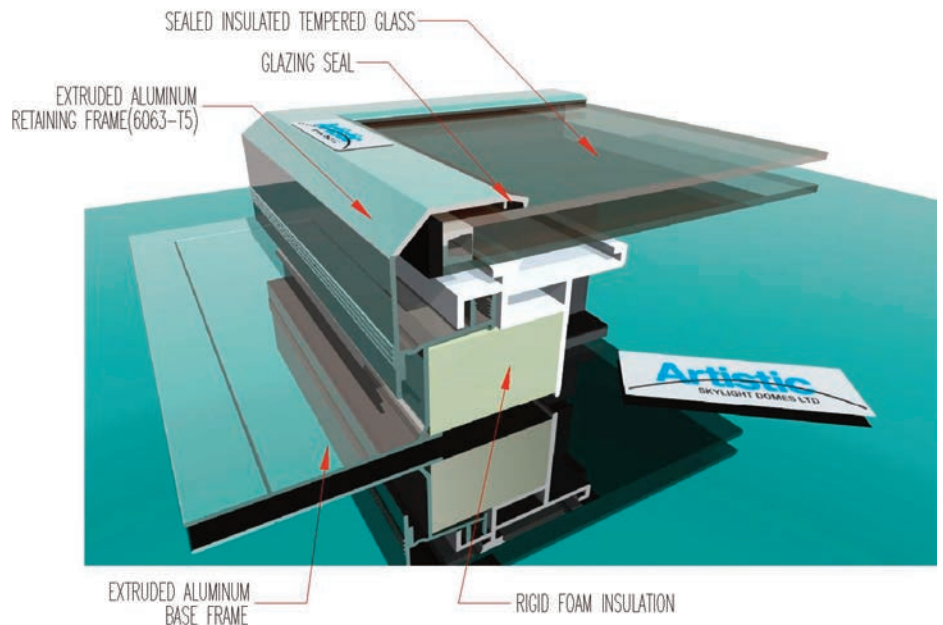



SIZE CHART:



Model	2036	2052	2828	2836	2852	2860	2876	2896	3636	3642	3652	3660	3676	3696	4242	4252	4260	4280	5252
Rough Opening	14 1/4" x 30 1/4"	14 1/2" x 46 1/4"	22 1/4" x 22 1/4"	22 1/4" x 30 1/4"	22 1/4" x 46 1/4"	22 1/4" x 55"	22 1/4" x 69 1/2"	22 1/4" x 89 1/2"	30 1/4" x 30 1/4"	30 1/4" x 37"	30 1/4" x 46 1/4"	30 1/4" x 55"	30 1/4" x 69 1/2"	30 1/4" x 89 1/2"	37" x 37"	37" x 46 1/4"	37" x 55"	37" x 75"	46 1/4" x 46 1/4"
Max. Outside Curb	18" x 34"	18" x 50"	26" x 26"	26" x 34"	26" x 50"	26" x 58 1/4"	26" x 73 1/4"	26" x 93 1/4"	34" x 34"	34" x 40 1/4"	34" x 50"	34" x 58 1/4"	34" x 73 1/4"	34" x 93 1/4"	40 1/4" x 40 1/4"	40 1/4" x 50"	40 1/4" x 58 1/4"	40 1/4" x 78 1/4"	50" x 50"
PVCCM / FF	•	•	•	•	•	•	•	•	•	•	•	•	•	•	•	•	•	•	•
P-PVCCM / P-FF																			
V-PVCCM																			
V-PVCSR																			
PVCSR / SR	•	•	•	•	•	•	•	•	•	•	•	•	•	•	•	•	•	•	•
G-PVCCM																			
G-FF																			
G-PVCSR	•	•	•	•	•	•	•	•	•	•	•	•	•	•	•	•	•	•	•
G-SR																			
GV-PVCCM																			
GV-PVCSR																			
CL / CL-FF	•	•	•	•	•	•	•	•	•	•	•	•	•	•	•	•	•	•	•



Model	5260	5276	5280	5296	6060	6076	6096	7272	7296	8080	9696
Rough Opening	46 1/4" x 55"	46 1/4" x 69 1/2"	46 1/4" x 75"	46 1/4" x 89 1/2"	55" x 55"	55" x 69 1/2"	55" x 89 1/2"	67" x 67"	67" x 89 1/2"	75" x 75"	89 1/2" x 89 1/2"
Max. Outside Curb	50" x 58 1/4"	50" x 73 1/4"	50" x 78 1/4"	50" x 93 1/4"	58 1/4" x 58 1/4"	58 1/4" x 73 1/4"	58 1/4" x 93 1/4"	70 1/4" x 70 1/4"	70 1/4" x 93 1/4"	78 1/4" x 78 1/4"	93 1/4" x 93 1/4"
PVCCM / FF	•	•	•	•	•	•	•	•	•	•	•
P-PVCCM / P-FF											
V-PVCCM											
V-PVCSR											
PVCSR / SR	•	•	•	•	•	•	•	•	•	•	•
G-PVCCM											
G-FF											
G-PVCSR	•	•			•						
G-SR											
GV-PVCCM											
GV-PVCSR											
CL / CL-FF	•	•	•	•	•	•	•	•	•	•	•



## Model V-PVCSR (vinyl base frame)

### Features:

- Incorporate a heavy duty corrosion resistant chain drive operating mechanism, pin pivot hinge system and removable insect screen
  - The skylight shall d high-impact extruded vinyl curb frame (superior in thermal conductivity to aluminum) which incorporates a high capacity, 8 degree sloped condensation gutter with drainage to exterior, and co-extruded rubber draft seal and a 3" mounting flange
  - Mill finish (optional baked enamel) , 6063-T5 aluminum alloy with heliarc welded corners
- Complete details and specifications are available on Model V-SR (aluminum curb frame)
  - To specify glass glazing option, add prefix "G" to model code. See page 3, for 'Glass Performance' options
  - Optional features include 6'-10' manual or electric extension poles, electric and remote control system

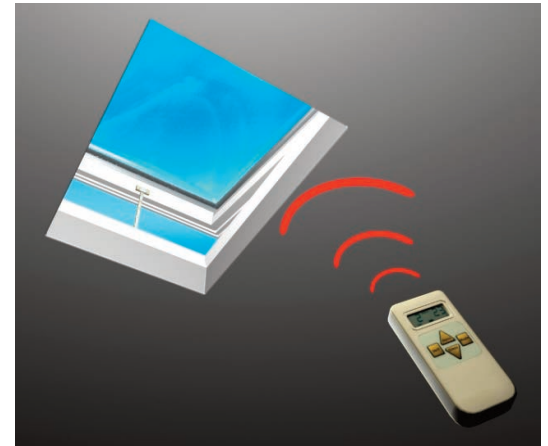
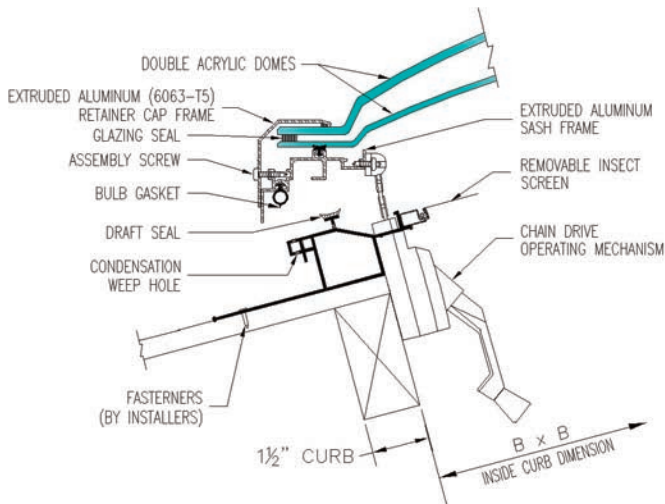
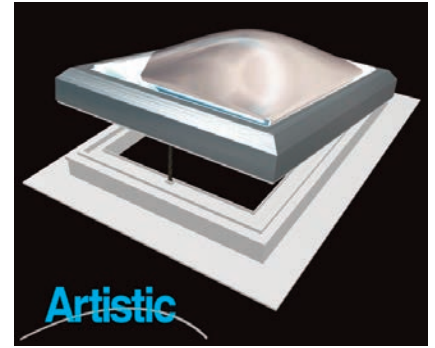

Remote controlled and Rain Sensor options on Models V-PVCSR

## Model GV-PVCSR (vinyl base frame)

### Features:

- Available in double high performance tempered glass glazing system, see page 3, for 'Glass Performance' options
- Consist of rigid high-impact extruded vinyl base frame
- Retaining cap frame shall be extruded, mill finish (optional baked enamel) aluminum alloy with heliarc welded corners

PARTICULAR
1. GLASS GLAZING
2. 1/8" x 1/4" DOUBLE FACE VINYL FOAM GLAZING TAPE
3. EXTRUDED ALUMINUM RETAINING FRAME-MEDIUM (6063-T5 ALLOY)
4. NEOPRENE SETTING BLOCK (1/4"x1"x1 1/2") BACK ADHERED
5. ALUMINUM SPACER WITH POLYSULFIDE SEALANT
6. #8 - 18 x 3/4" ASSEMBLY SCREW
7. EXTRUDED ALUMINUM SASH FRAME (6063-T5 ALLOY)
8. BULB GASKET (FLEXIBLE PVC-UV STABLE)
9. EXTRUDED RIGID THERMAL PVC SELF FLASHING FRAME
10. SANTOPRENE CUP GASKET (UV STABLE)
11. #8 - 18 x 1/2" ASSEMBLY SCREW
12. CO-EXTRUDED RUBBER DRAFT SEAL
13. CHAIN DRIVE OPERATING MECHANISM
14. TELESCOPING POLE-HOOK HANDLE
15. EXTRUDED RIGID PVC SASH THERMAL FRAME COVER (UV STABLE)
16. INSECT SCREEN

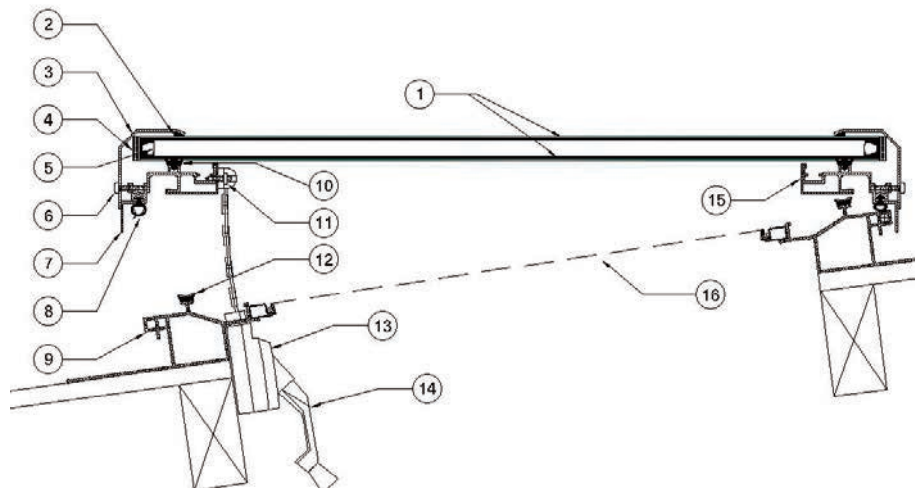

## CUSTOM ENGINEERED SKYLIGHT SYSTEMS

With the use of our in house designed tubular structural skylight system we can satisfy a wide variety of shapes such as pyramids, polygons, and hipped ridge. All aluminum frame members are extruded with complete thermal break and can be painted to match almost any colour and finish. Our exclusive frame design can accommodate any slope between 18 and 60 degrees with curb openings of up to 16', and enables us to offer an industry exclusive 2 year warranty. Glazing is available in a wide variety of options, including safety glass, acrylic, and polycarbonate, in single or double glazed. Complete details and specifications are available upon request.

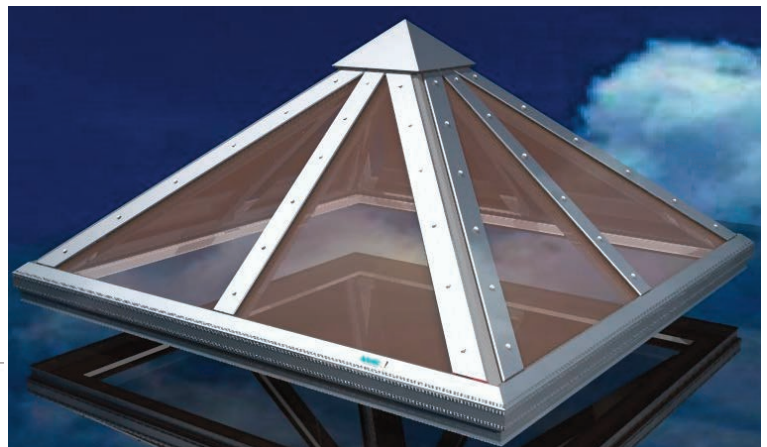
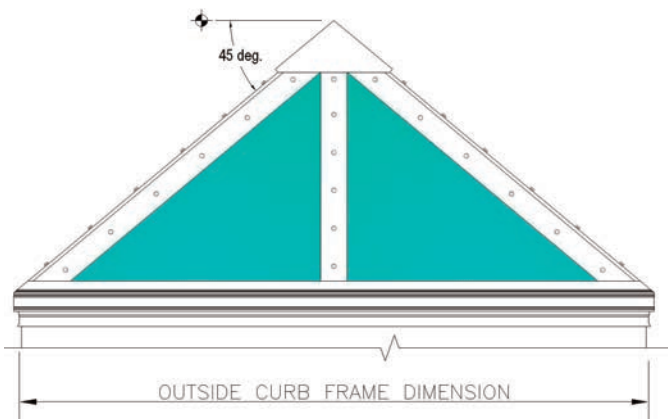
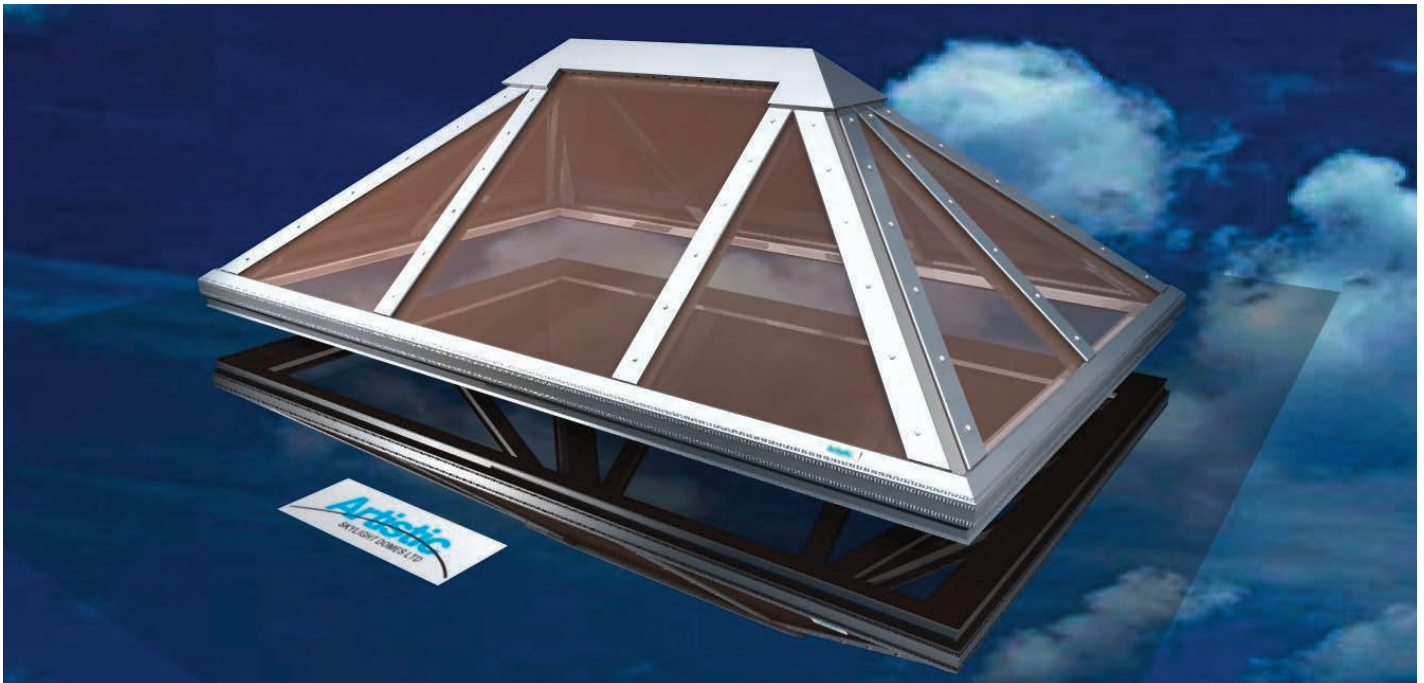
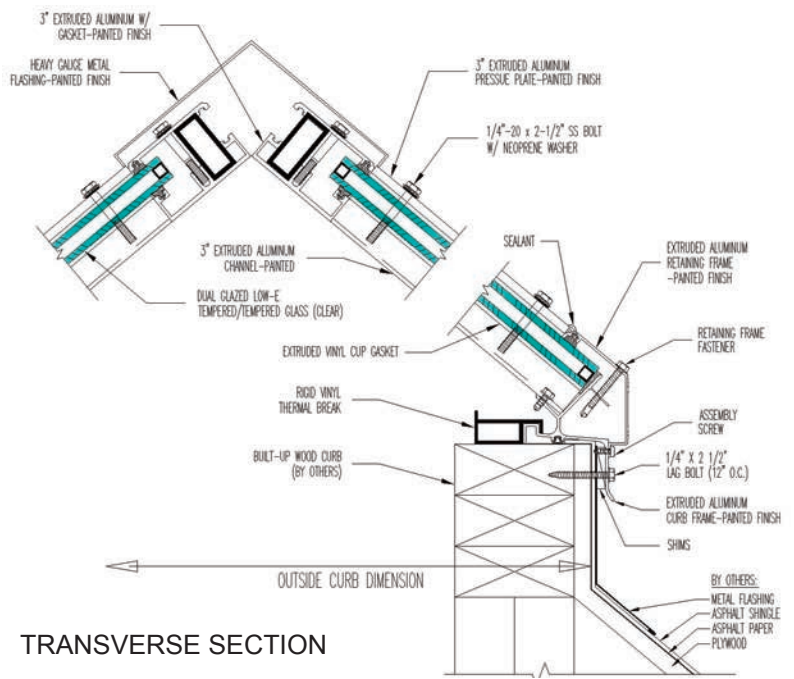



# Insulated Curb Skylights

Model CL and C are supplied complete with a prefabricated, insulated aluminum curb, for use on commercial/industrial applications.

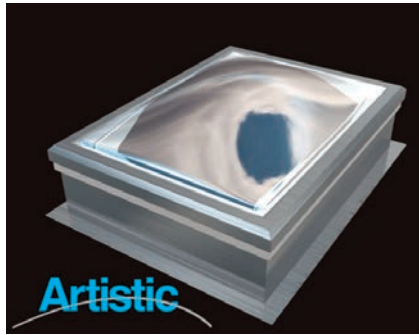

## Model CL

### Features:

- Glazing available in sealed double or triple acrylic domes of clear, white, bronze
- Vinyl curb is a rigid high-impact extruded vinyl curb frame (superior in thermal conductivity to aluminum)
- Retaining cap frame shall be extruded, mill finish (optional baked enamel)

- Curb shall be 9" high (optional 12") mill finish aluminum, 2 pieces construction of 0.050 outer wall and 0.050 inner wall, with 2" thick fiberglass insulation and 3" aluminum mounting flange.

- To specify Frost-free frame option, add prefix "FF" to model code (CL-FF)
- To specify pyramid option, add prefix "P" to Model code

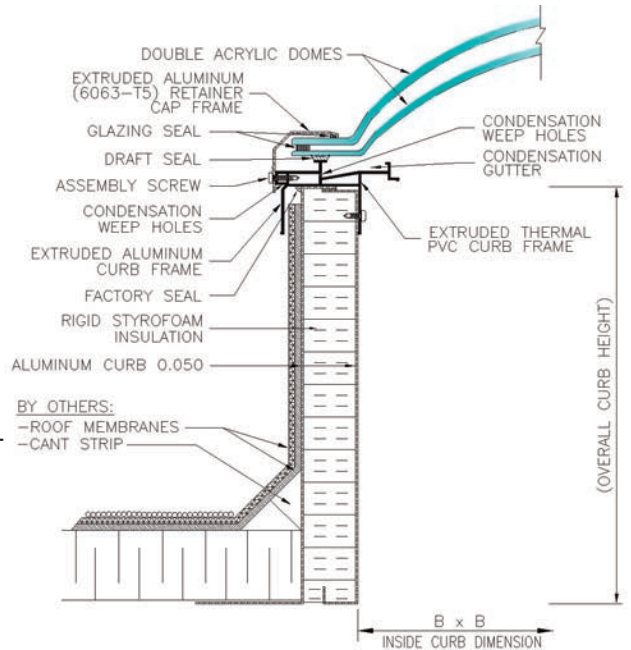

## Model C

### Features:

- Glazing available in sealed double or triple acrylic domes of clear, white, bronze
- Vinyl curb is a rigid high-impact extruded vinyl curb frame (superior in thermal conductivity to aluminum)
- Retaining cap frame shall be extruded, mill finish (optional baked enamel)

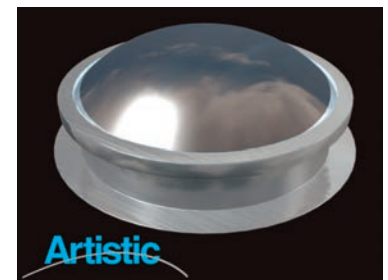

- Curb shall be 9" high (optional 12") mill finish aluminum, 2 pieces construction of 0.050 outer wall and 0.050 inner wall, with 2" thick fiberglass insulation and 3" aluminum mounting flange

- To specify curb mount by others, use Model CCM

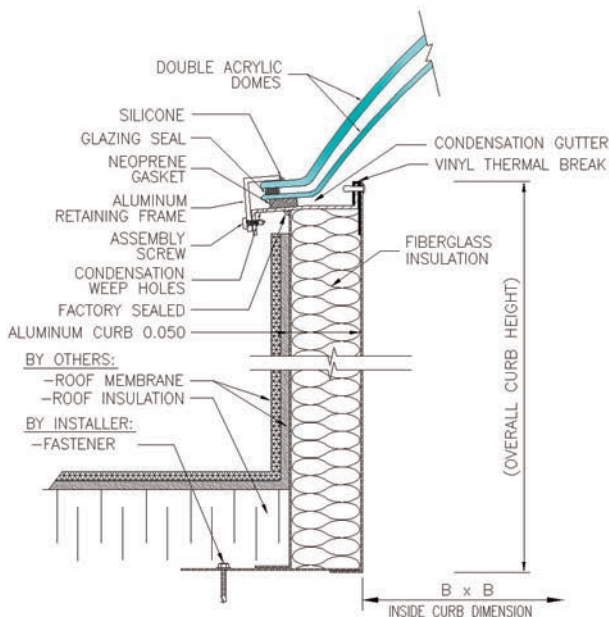

# Continuous Skylights

## Model CF-FF-VE

This model incorporates a barrel vault design to achieve unlimited lengths with standard widths between 2" and 8".

### Features:

- Available in sealed double acrylic domes (or sealed triple domes) of clear, white, bronze
- Consisting of corrosion resistant extruded aluminum curb frame
- Curb frame shall have an extruded rigid vinyl thermal break
- Retaining cap frame shall be extruded, mill finish (optional baked enamel) aluminum alloy
- Mullions shall consists of 3" mill finish (optional baked enamel), pre-arc'd, extruded aluminum channel and pressure plate spacing to be approximately 4' on centre

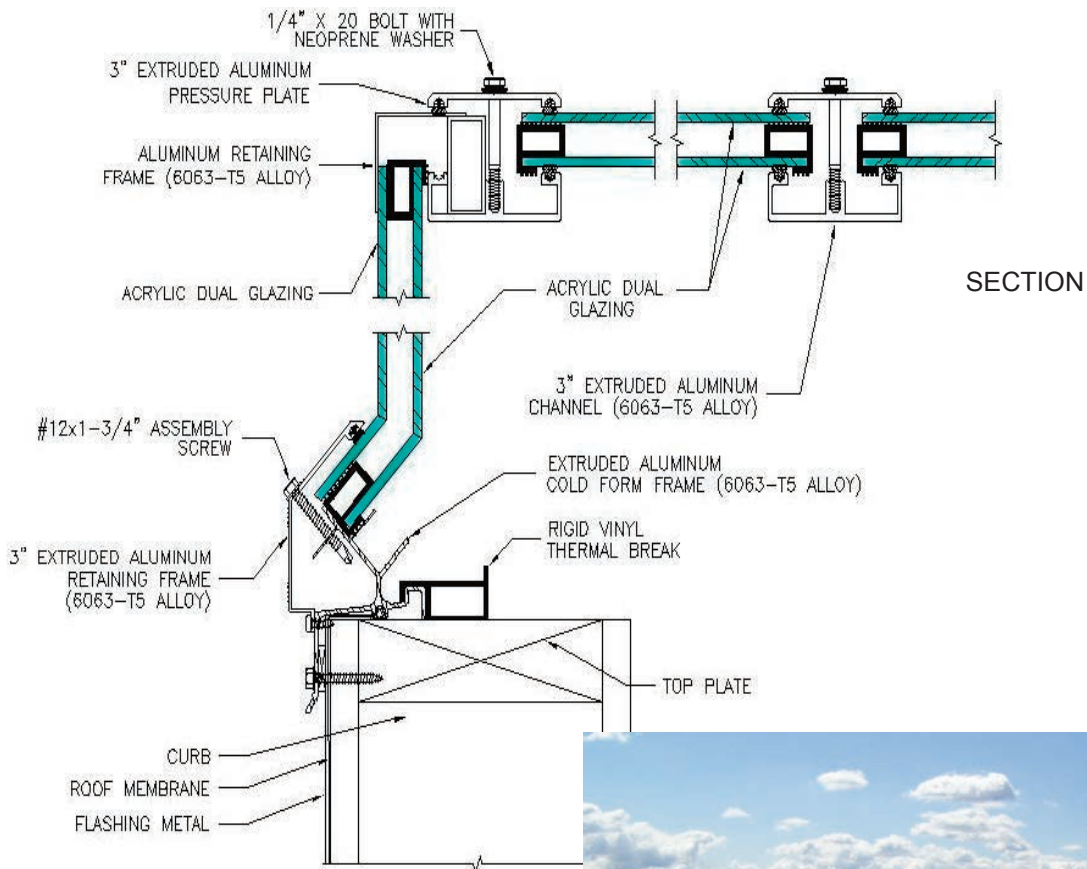
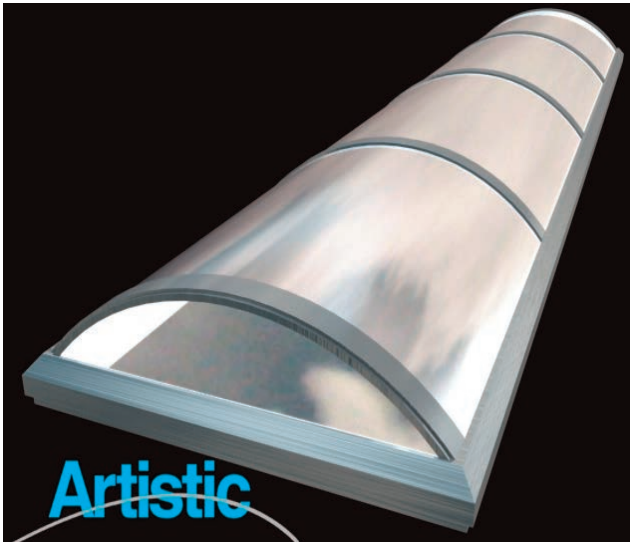



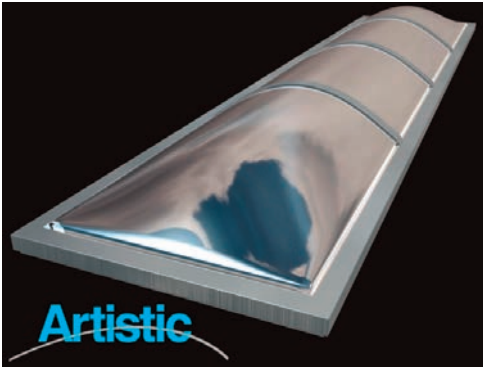

# Continuous Skylights

## Model CU

This model incorporates a barrel vault design to achieve unlimited lengths with standard widths between 2" and 8".

### Features:

- Available in sealed double acrylic domes (or sealed triple domes) of clear, white, bronze
- Consisting of corrosion resistant extruded aluminum curb frame
- Curb frame shall have an extruded rigid vinyl thermal break

- Retaining cap frame shall be extruded, mill finish (optional baked enamel) aluminum alloy
- Mullions shall consists of 3" or 4" mill finish (optional baked enamel), pre-arc'd, extruded aluminum channel and pressure plate with resilient neoprene and vinyl gaskets

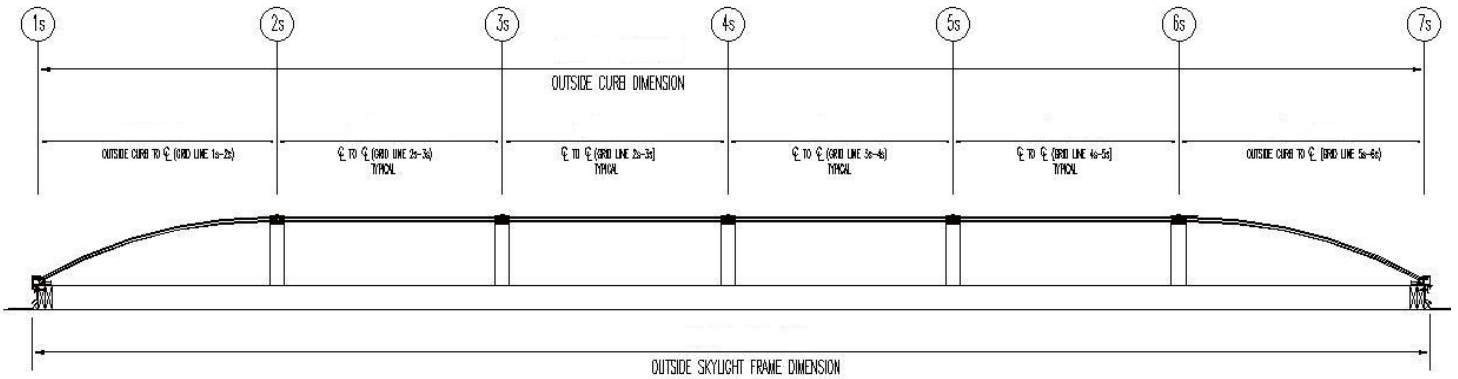

LONGITUDINAL SECTION

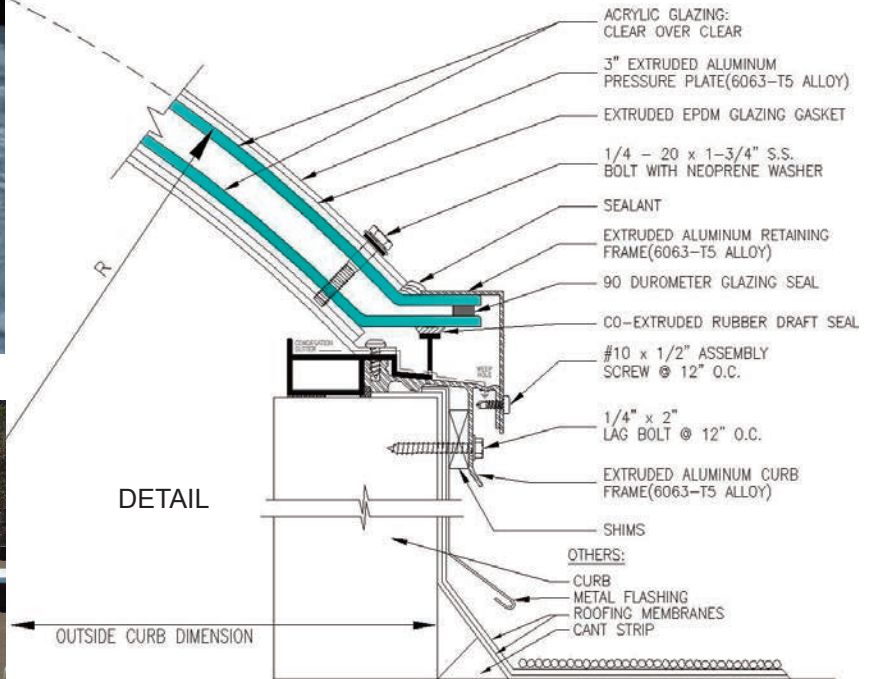

# Butted & Clustered Skylights

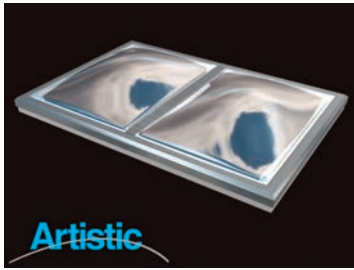

Model FF-Butted

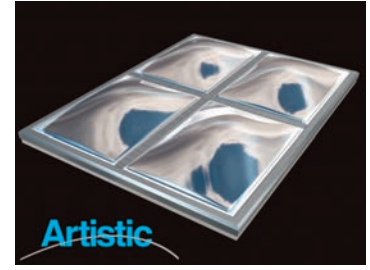

Model FF-Clustered

Our butted and clustered system provides a cost effective alternative to 'custom' skylights by combining two or more standard skylight sizes to form one unit.

**Features:**

Skylight shall be factory assembled Model FF-BUTTED or FF-CLUSTERED specified as follows:

- Extruded aluminum channel and pressure plate, 6063-T5 alloy, with resilient neoprene gaskets
- Mullions shall consist of 3" mill finish (optional baked enamel)

\* To specify pyramid option, add prefix "P" to model code

\* To specify glass glazing option, add prefix "G" to model code. See page 3, for "Glass Performance" options

**SECTION VIEW**

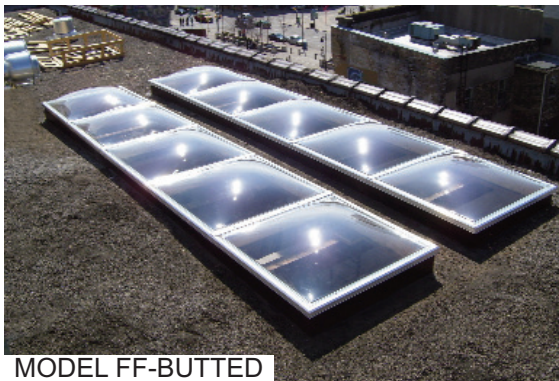
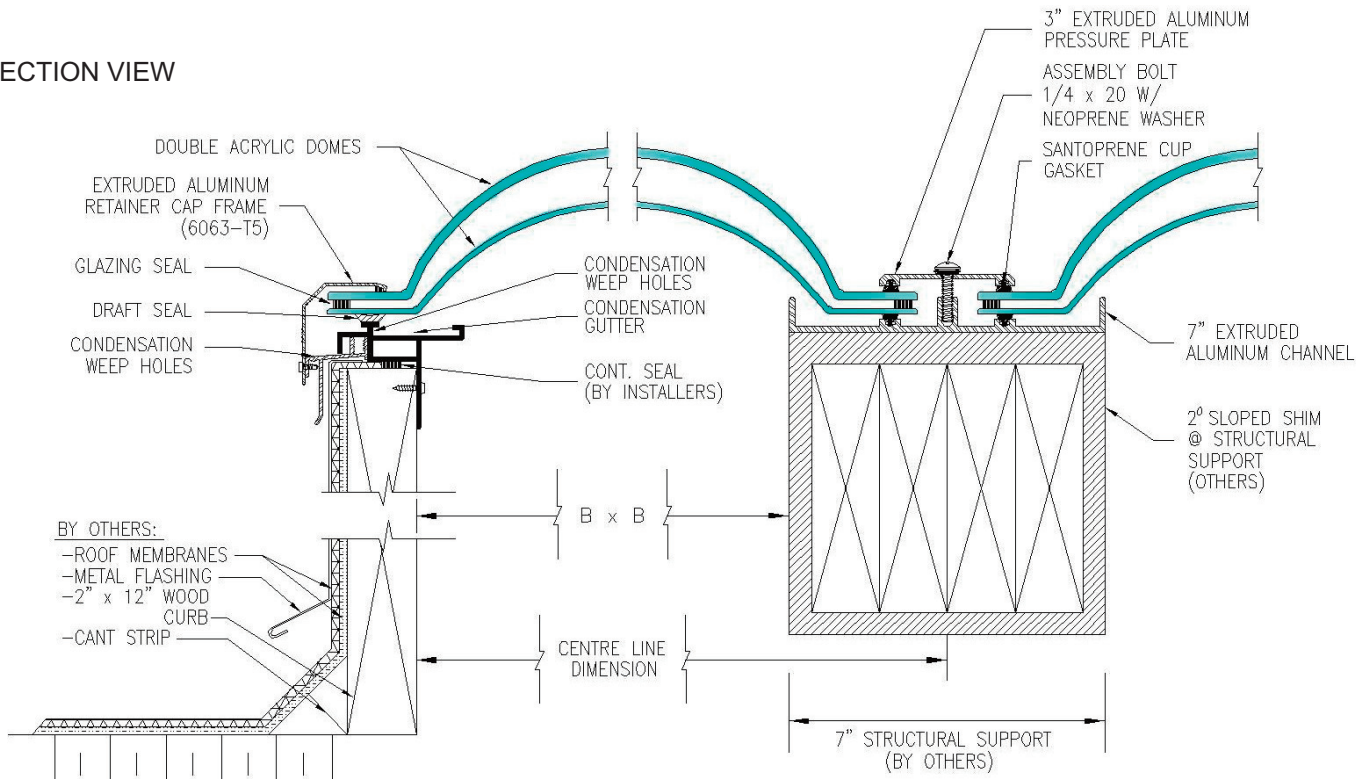

MODEL FF-BUTTED



MODEL FF-CLUSTERED



# SPECIFICATIONS

## PART 1 - GENERAL

### 1.1 DESCRIPTION OF WORK

- A. Furnish all labour, material, plant and services required to complete fabrication and shipment of skylights as specified herein.
- B. Work is limited to skylight system only; and includes the following:
  - 1. Thermal aluminum vinyl frame system
  - 2. Glass, acrylic or polycarbonate glazing and glazing gaskets.
  - 3. Factory installation or installation by factory approved contractor with site supervision as required.

### 1.2 QUALITY ASSURANCE

- A. The skylights specified herein shall be manufactured by ARTISTIC SKYLIGHT DOMES LTD., of Etobicoke, Ontario. Substitute manufacturers shall not be considered without written approval of at least 10 days prior to bid date.
- B. Qualifications include a minimum of 5 years experience in skylight manufacturing, qualified by having performed similar work and having experienced workmen to perform work of type required by contract documents and licensed where appropriate.

### 1.3 SUBMITTALS

- A. Copies of shop drawings shall be submitted for the architect's approval prior to starting fabrication.
- B. Submit samples of products as required by architect.

### 1.4 WARRANTY

- A. Artistic skylight Domes Ltd., unit skylights are guaranteed for a period of 5 years from date of purchase against defects in materials or workmanship.
- B. All Custom Skylight Systems are guaranteed for a period of 2 years from date installation against leakage and defects in materials or workmanship.
- C. These guarantees are limited to repair or replacement, at our discretion, and does not cover any freight, installation, or consequential damages.

## PART 2 - PRODUCTS

### 2.1 MATERIALS

- A. All framing systems shall be extruded aluminum, 6063-T5 alloy, with extruded rigid vinyl thermal break.
- B. All exposed aluminum surfaces shall be standard mill finish or optional brown or clear anodized. Custom finishes and colours are also available.
- C. Sealants, as designated on drawing, shall be neutral cure architectural grade silicone.
- D. Fasteners shall be stainless steel or cadmium plated steel. All exposed fasteners to match specified colour of adjacent aluminum.
- E. Glazing shall be:
  - 1. Plastic glazed units to be double glazed (acrylic)(polycarbonate-cold formed only) of thickness and colours as required design criteria.

- 2. Glass glazed systems shall be double glazed of thickness and colours as required by design criteria.

### 2.2 FABRICATION

- A. Skylights shall be factory assembled and shipped as such. Work which cannot be permanently assembled will be shipped in pre-assembled sections to minimize field assembly .
- B. Materials shall be as specified in Part 2.1.

## PART 3 - EXECUTION

### 3.1 INSTALLATION

- A. Installer shall inspect area to receive skylights to determine that the conditions are in accordance with shop drawings and specifications. Any variance shall be recorded in writing and corrections made before beginning installation.
- B. Installation shall be in strict accordance with these specifications and the manufacturers shop drawings and installation instructions.
- C. All materials provided by installer shall be in accordance with those shown on the shop drawings.
- D. Installer shall remove all labels and protective packaging from components and shall leave the installation free of all heavy construction dirt and sealant smears.
- E. Final cleaning and physical protection of all installed materials shall be performed by the general contractor.

#### ARTISTIC SKYLIGHT DOMES LTD.

reserves the right to change or discontinue any product without prior notice



St. Luke School, Oakville, Ontario



Harper House, Toronto, Ontario



City Centre, Ottawa, Ontario

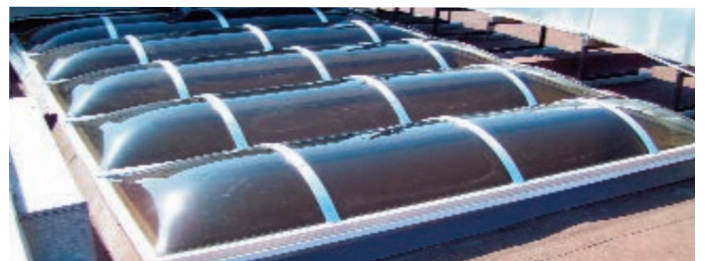

CFB, Kingston, Ontario

#### DISTRIBUTOR:



255 Regina Rd.  
Woodbridge, Ontario, Canada L4L 8M3  
Tel: (416) 747-7233 Fax:(416) 747-6630  
Email:info@artisticskylight.com  
Website:www.artisticskylight.com